

DIMENSIONES Y ELEVACIONES EN METROS
DIMENSIONS AND ELEVATIONS IN METRES

VAR 6° E

RWY 18 / 36

DISTANCIAS DECLARADAS / DECLARED DISTANCES			
RWY 18			RWY 36
3006	TORA	RECORRIDO DE DESPEGUE DISPONIBLE TAKE-OFF RUN AVAILABLE	3006
3006	TODA	DISTANCIA DE DESPEGUE DISPONIBLE TAKE-OFF DISTANCE AVAILABLE	3006
3006	ASDA	DISTANCIA DE ACELERACION PARADA DISPONIBLE ACCELERATE-STOP DISTANCE AVAILABLE	3006
3006	LDA	DISTANCIA DE ATERRIZAJE DISPONIBLE LANDING DISTANCE AVAILABLE	3006

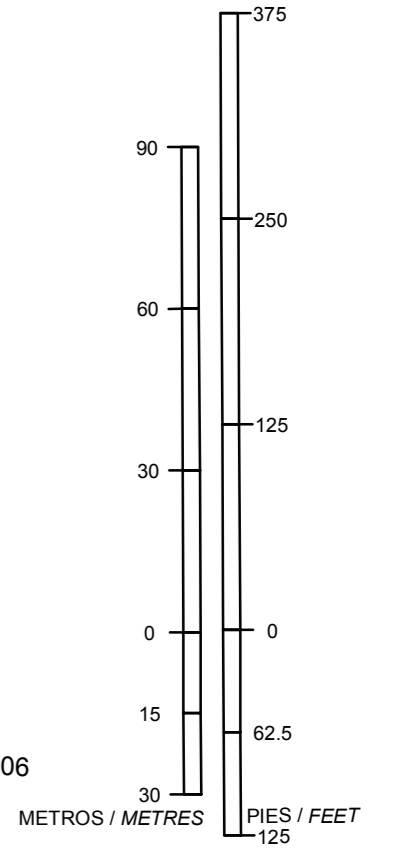
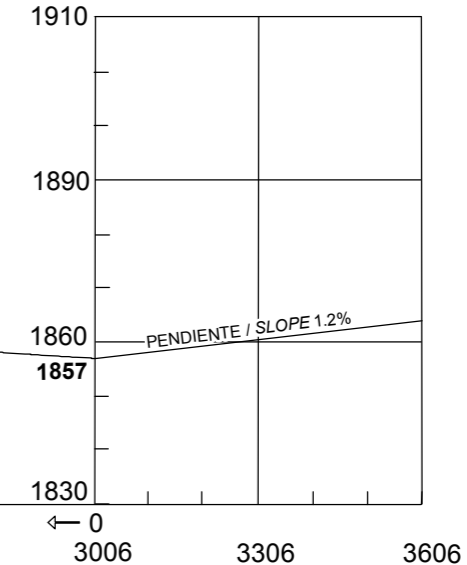
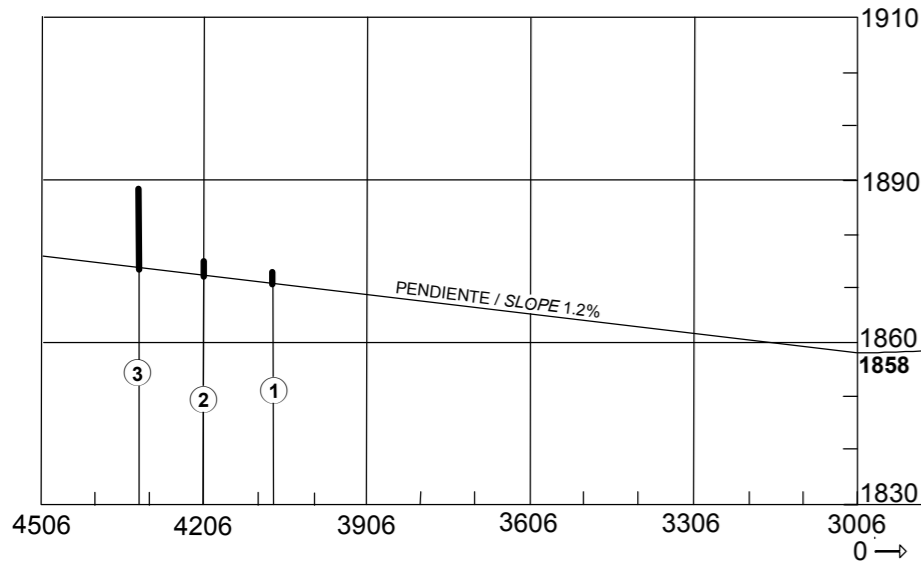

ESCALA VERTICAL / VERTICAL SCALE 1:1500

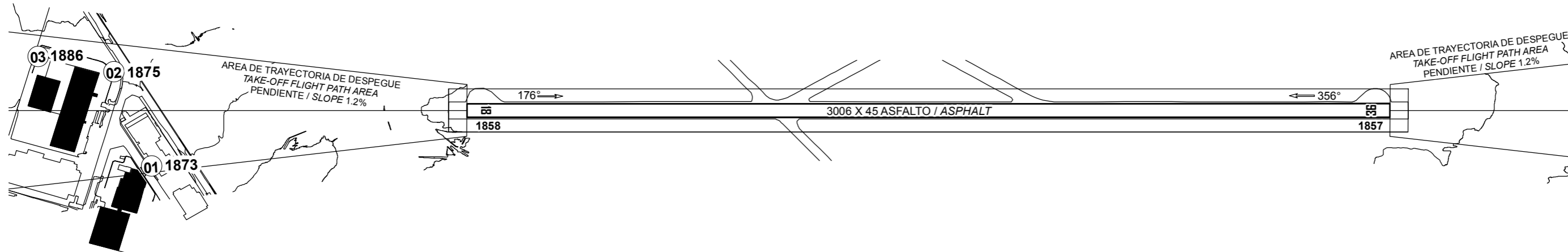

SIMBOLOGIA / LEGEND	
NUMERO DE IDENTIFICACION IDENTIFICATION NUMBER	① ALTITUD
POSTE, TORRE, CAMPANARIO, ANTENA, ETC POLE, TOWER, SPIRE, ANTENNA, ETC.	⊙
EDIFICIO O ESTRUCTURA GRANDE BUILDING OR LARGE STRUCTURE	■
FERROCARRIL RAILROAD	++
CURVA DE NIVEL DE TERRENO TERRAIN CONTOUR	~
TERRENO QUE PENETRA PLANO DE OBSTACULOS TERRAIN PENETRATING OBSTACLE PLANE	▲
ARBOL, ARBUSTO, ETC TREES, BUSH, ETC	*

Escala Horizontal / Horizontal Scale 1:15,000

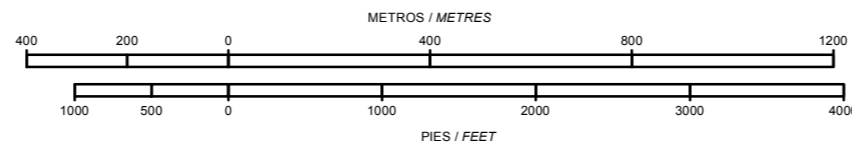

REGISTRO DE ENMIENDAS / AMENDMENT RECORD		
No.	FECHA / DATE	ANOTADA POR / ENTERED BY

ORDEN DE PRECISION
ORDER OF ACCURACY
HORIZONTAL 0.5 M
VERTICAL 0.5 M

CAMBIOS: CARTA NUEVA